



A **KGiSL** Enterprise



FRONT OFFICE SERVICE

The smart way to increase your revenues

ROBUST | PROFITABLE | STREAMLINED



KG Information Systems Private Limited

KG Campus, 365 Thudiyalur Road, Saravanampatti, Coimbatore – 641 035, Tamil Nadu, India

Phone: + 91- 422- 4419999 | Telefax: + 91- 422-2668325

E-mail: bss@kgisl.com | Website: www.kgisl.com





Client Profile:

A private practice pain management clinic based out of New Jersey with two pain management physicians practicing at five different office locations. The physicians see patients on five weekdays (except Friday and Sunday)

Business Situation:

The clinic was a busy practice and the Doctor's staffs were fully occupied in attending to the visiting patients on a daily basis and patient scheduling was inefficient. Besides, staff members were manually entering the caller information into the system. Inundated with various types of calls and staff turnover, the doctor's office was on the lookout for an appointment scheduling partner that would handle front office effectively.

The practice approached us in the year 2015 to establish and run front-desk operations

How we helped this client?

We offered a more streamlined process of scheduling to the practice enabling them to better serve its patients and reduce the amount of manual work.

- The first step was to perform an assessment of the current state of front-desk scheduling operations
- The assessment involved our consultancy team working with the practice to determine the scope of work
- The findings from assessment formed basis to setup centralized front-desk operations for this client in India with one FTE (Virtual Assistant with expertise handling patient calls) in the year 2015 (later after a year added a second FTE to accommodate the increase in number of calls)
- When someone calls the doctor's local phone number, the call gets automatically
- forwarded to our toll free number and we had set up an IVR to avoid missed calls
- The phone calls were answered representing the doctor's practice
- F Handled inquiries via Phone, Chat, SMS, Website, Apps
- F Patient appointments were confirmed 24 hours ahead to avoid No shows
- Missed appointments were converted by constant follow-ups / reminder calls to patients
- F Follow ups with established idle patients to improve appointments
- F Provided Back Office Support including
 - ❖ Maintaining patient demographics
 - ❖ Monitoring as well as sending faxes
 - ❖ Emailing medical record
 - ❖ Coordinating and arranging transport for Patients
 - ❖ Calling in prescriptions to the pharmacies
 - ❖ Helped Patient's fill forms via Patient Portal
- F Providing seamless support to Doctors including analytics and reporting that help manage patients effectively

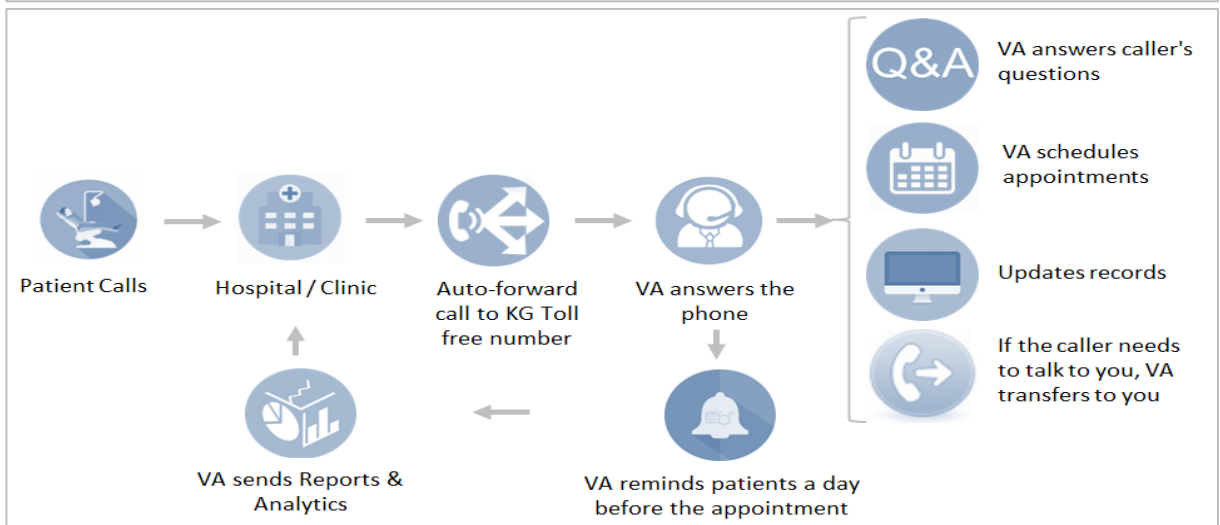
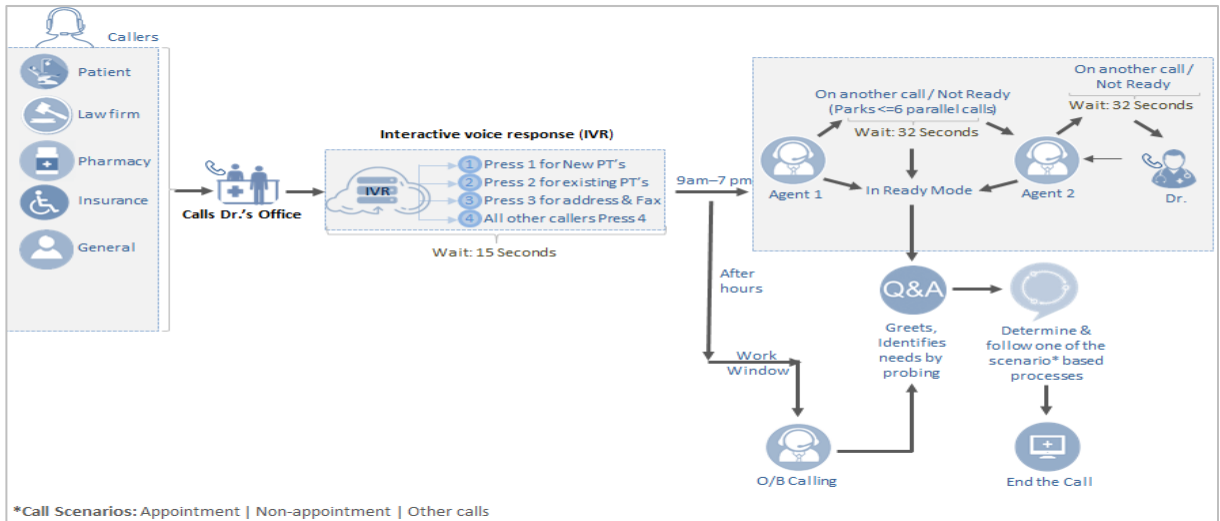

Results:

- Established KPI metrics to measure scheduling performance
- Effective handling of the front-desk offered competitive advantage in establishing the practice at two additional locations
- Offered centralized appointment scheduling to all five practice locations
- Quickly and flexibly scaled the operations based on seasonal inflow of calls. Added a second virtual assistant within an year to handle the increase in call volume (I/B & O/B)
- Provided 100% seamless service (supported by a shadow resource during absenteeism and breaks) and managed by a dedicated Account Manager
- Handled over 60000 calls per year
- Decreased missed calls rate from 26% to <1% post implementation of IVR(Interactive voice response) process and improved patient service levels
- Reduced no-shows by 12%
- Checkouts increased by 94%

The impact we had on Doctor's practice and the patient experience, the business continues to expand.



Key Performance Indicators (KPI Metrics) - Defined by Client

KPI Metrics	Targets	Achieved
Calls Answered	100%	100%
No-Show Follow up	100%	100%
Quality	90%	93%

Sample Production Report

EFFORTS

#	Total Calls	Inbound	Outbound	Inbound		Outbound	
				Patient Calls	Other Calls	Patient Calls	Other Calls
Month	5255	2231	3024	781	1450	2722	302
Agent 1	110	88	22	31	57	20	2
Agent 2	129	26	103	9	17	93	3

RESULT

Appointment	Check-Out	NO Show
1300	1222	78
	94%	6%

OUR VALUE PROPOSITION

- ✓ Full revenue cycle solution from patient scheduling to collections
- ✓ Flexibility in using any billing software
- ✓ Certified coders on needs basis
- ✓ Efficiently reduces aging on A/R to maximize cash flow
- ✓ 24 hours turn-around-time
- ✓ Strict quality control standards
- ✓ Provide daily, weekly and monthly reports
- ✓ Gain performance efficiencies

About Us

KGiSL is a leading provider of Business Support Services (BSS) and Global Software Services (GSS) and is a part of the \$750M flagship KG Group of Companies which is in business for over 80 years. KG as a group has been in the healthcare business for the past four (4) decades, building on this bedrock of seasoned experience, the enterprise has established and successfully partnered with individual practitioners in USA easing out their complexities in revenue cycle management process.



HIPAA Compliant



Saves Operational Costs by 50%



Process engineered and streamlined operations



24 x 7 Support



Business Analytics



Superior talent: Credentialed staff with Domain Expertise

